

---

*Technical Memorandum*

# Uranium Treatment – Phase II Conceptual Design

Prepared for  
**City of Las Cruces**

Utilities Division  
680 N. Motel Boulevard  
P.O. Box 20000  
Las Cruces, NM 88004

June 2007

**CH2MHILL**  
445 Executive Center Boulevard, Suite 110  
El Paso, TX 79902-1003

---

*Technical Memorandum*

# **Uranium Treatment – Phase II Conceptual Design**

Submitted to  
**City of Las Cruces**

June 2007

Copyright 2007 by CH2M HILL, Inc.

Reproduction and distribution in whole or in part beyond the intended scope of the contract without the written consent of CH2M HILL, Inc. is prohibited.

---

**CH2MHILL**

## Uranium Treatment - Phase II Conceptual Design

PREPARED FOR: City of Las Cruces - Utilities Department

PREPARED BY: CH2M HILL

COPIES: Dan Santantonio/City of Las Cruces  
Gilbert Morales/City of Las Cruces  
file

DATE: June 20, 2007

PROJECT NUMBER: 340891.05.01

### Purpose

The purpose of this technical memorandum (TM) is to prepare conceptual designs and recommendations for the implementation of new treatment facilities for the City of Las Cruces (City). These treatment facilities will target removal of uranium from two existing groundwater wells (Wells No. 20 and 44). This TM provides information on the treatment equipment, facility layout, opinion of construction cost, and implementation of the system.

### Background

The Phase I evaluation entitled, "Uranium and PCE Treatment - Phase I Evaluation of Treatment Technologies" completed June 26, 2006, by CH2M HILL selected non-regenerating ion exchange as the preferred treatment technology to remove uranium from the City's groundwater wells. This TM provides the next stages of costs and layout for these facilities.

### Treatment Process

The selected treatment process, non-regenerating ion exchange (IX), is a treatment process that can effectively remove dissolved uranium from a drinking water supply. The process is listed as a BAT for uranium removal by the U.S. Environmental Protection Agency (EPA).

IX is a physical/chemical process by which an ion in the media is exchanged for a uranium ion in the feed water. In this case of uranium removal from groundwater, the uranium ion is a negative ion, or anion, since the pH of the water is above 6.5. This further defines the IX process as an Anion Exchange (AX) process. The media used in an IX system consists of a synthetic resin which has been designed to preferentially adsorb uranium. The IX process operates by continually passing feed water through a bed of ion exchange resin in an upflow mode until the media is exhausted with uranium. Exhaustion occurs when most sites, or ions, on the resin beads have been filled, or exchanged, by uranium ions. The

exchanged ions that have been replaced by uranium become part of the treated water solution. These ions are considered harmless in a potable water system.

A non-regenerative IX process differs from a regenerating IX process in that there are no backwash pumps, backwash tanks, or chemical additions required. This makes a non-regenerative process a simple single pass system, requiring significantly less operator skill and attention from a mechanical standpoint when compared to a regenerating process. See Figure 1 for a process flow diagram of a non-regenerating IX system for this application.<sup>1</sup>

The only waste product from a non-regenerative IX facility is the exhausted media. There is no liquid waste stream since the IX resin is not regenerated with a brine solution. Typically, non-regenerative IX media used for uranium removal would be designed to last up to a year or more before replacement and disposal is required.

There are some IX suppliers for uranium removal that offer operations, maintenance, and disposal support for radionuclide removal systems. The suppliers establish long term contracts (i.e. 10 year, 15 year, 20 year, etc.) with municipalities that require the supplier to monitor the water quality results flowing into and out of the IX system and replace the media at a predetermined exhaustion threshold. The supplier is responsible for removing, packaging, transporting, and disposing of the spent media. The supplier is also responsible for retaining staff that is trained in handling radioactive wastes of this nature. Certain suppliers have intimate knowledge of the abundant regulations surrounding the handling, transportation, and disposal of wastes containing radionuclides. Under such a contract, it is the responsibility of the supplier to meet the regulations of the radionuclides rule. See Appendix A for a list of manufacturers that supply IX equipment designed to remove uranium.

There are important considerations when assessing the applicability of the IX process for uranium removal. Water quality parameters such as pH, competing ions such as sulfates, media type, alkalinity, and influent uranium concentration, each must be considered when evaluating the efficacy of an IX system for uranium removal. Other factors to consider include the affinity of the media for uranium, secondary water quality effects, and design operating parameters. These elements were considered and evaluated using the information gathered from the Water Remediation Technology (WRT) pilot study program reports for both Wells No. 20 and 44 ("Pilot Study Report for Z-92™ Uranium Treatment Process conducted at City of Las Cruces, New Mexico Well No. 20", February 7, 2007, by WRT, and "Pilot Study Report for Z-92™ Uranium Treatment Process conducted at City of Las Cruces, New Mexico Well No. 44", February 7, 2007, by WRT). The results of the pilot studies indicate that non-regenerative IX is an applicable process for removing uranium from Wells No. 20 and 44. There don't appear to be any factors that would limit the use of non-regenerative IX for this application.

---

<sup>1</sup> Flow diagram is based on non-regenerating IX system design by Water Remediation Technology (WRT).

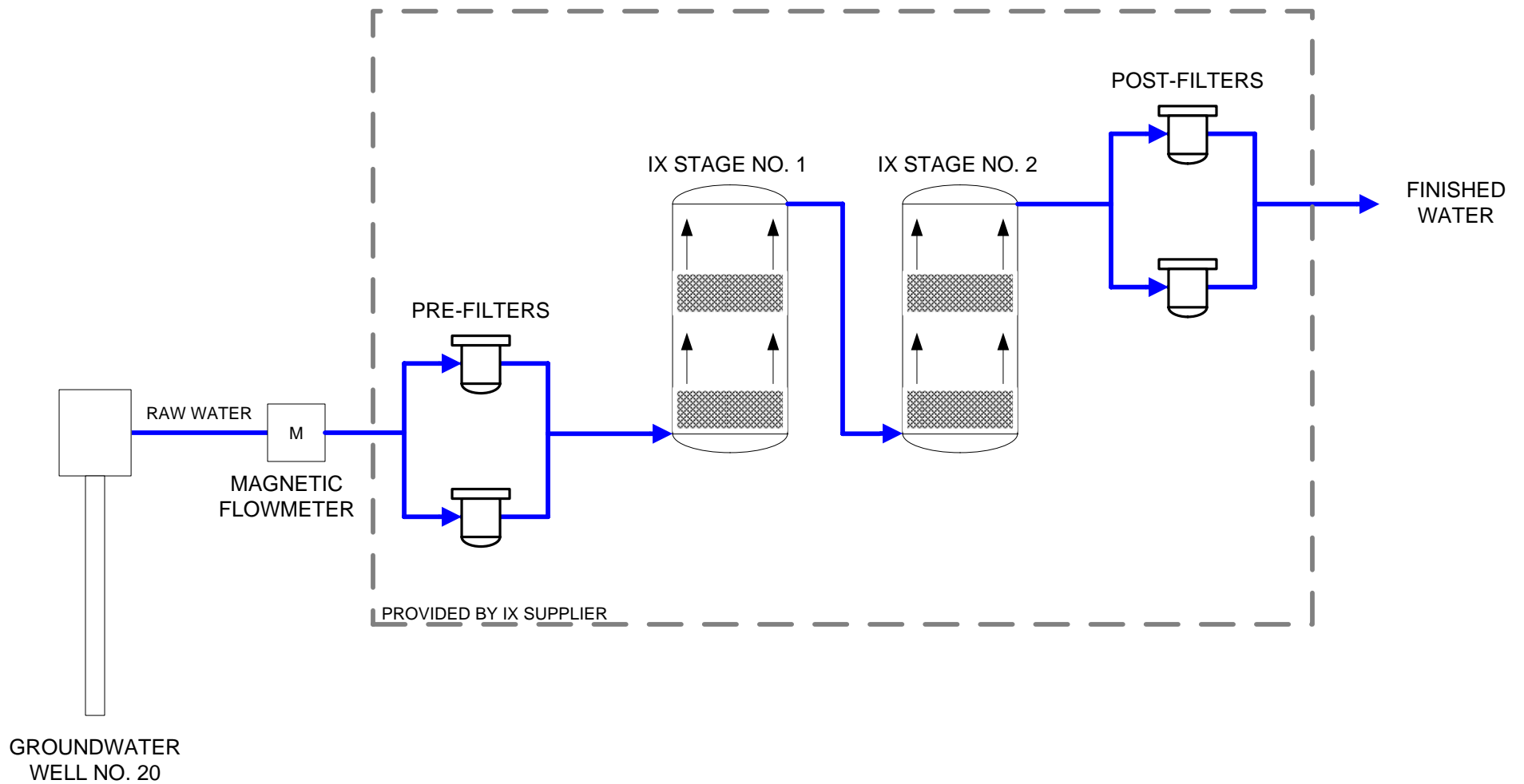

Figure 1 – Non-Regenerative IX Process Flow Diagram

## Conceptual Design Criteria

Historic water quality data and the results from the WRT pilot studies for Wells No. 20 and 44 were used to develop the conceptual design for uranium treatment facilities at each well site. See Table 1 for a summary of the conceptual design criteria for these facilities.

TABLE 1  
Conceptual Design Criteria for Well Head Uranium Treatment

Well No.	Well Capacity (gpm)	Annual Utilization <sup>(1)</sup>	Annual Production (MG)	Avg. U Conc. (µg/L) <sup>(2)</sup>	No. of IX Stages Required	IX Tank Diameter (feet)	IX Tank Height (feet)
20 (Alt. #1)	1,050	32.0%	176.46	50	2	12	9
20 (Alt. #2)	1,050	32.0%	176.46	50	4	12	9
44	780	22.7%	93.23	47	2	10.5	9

(1) Annual utilization rates for each well taken from historical utilization data.

(2) Average uranium concentration for Well No. 20 taken from historic data and from WRT pilot study data. Average uranium concentration for Well No. 44 taken from historic data only. Uranium levels in Well No 44 during pilot testing were substantially lower than historical levels. It was assumed that the uranium levels in Well No. 44 could return to within historical limits. Therefore, the conceptual design for Well No. 44 assumes uranium concentrations at historical levels.

Well No. 20 contains slightly higher levels of sulfates than Well No. 44. Sulfates compete with uranium ions for sites on the IX media. The sulfate competition can lead to a more rapid loading of the IX media and would require the media to be replaced more often. Two alternatives were developed for Well No. 20 in response to the sulfate competition. Alternative #1 is a 2-stage design and Alternative #2 is a 4-stage design. Alternative #1 would require that the media be exchanged more frequently than the media in Alternative #2. This is due to the fact that there is less media in the 2-stage system and the increased concentration of sulfate ions may load the media at a higher rate. This would result in higher annual operations and maintenance (O&M) costs for Alternative #1. Alternative #2 has two more stages than Alternative #1. This would result in higher capital costs for Alternative #2, but lower annual O&M costs since there is more media and it will take longer to load, even with sulfate competition.

A 4-stage design alternative is not required for Well No. 44 since the sulfate levels in this well are low and do not warrant the additional media. A 2-stage design will provide adequate capacity for uranium ions, including any competition from sulfate ions.

The costs for the treatment systems are discussed in the following sections. See Figure 1 in the previous section for an example process flow diagram for Alternative #1 (2-stage). See Figure 2 for the process flow diagram for Alternative #2 (4-stage).

The treatment systems for each well would be provided with the following items:

- Epoxy coated carbon steel tanks for each stage
- 304 stainless steel piping between each stage
- Disconnect switches for the system

- Alarms for low flow
- Controls to allow remote operation from the City's existing SCADA system
- A flow meter to measure the discharge from the treatment system

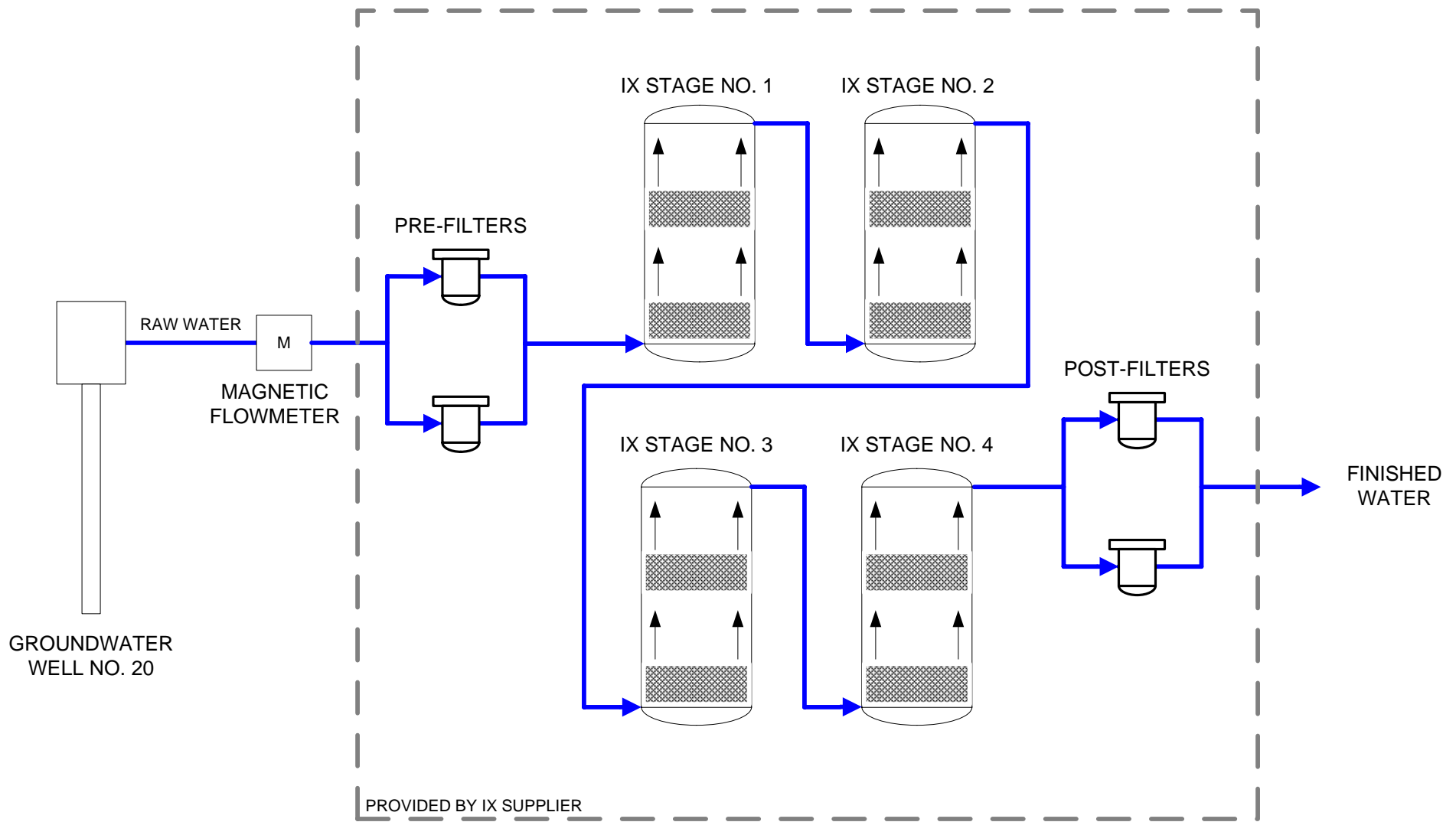

Figure 2 – Well No. 20 Process Flow Diagram (Alternative #2)



## Treatment Facility Layout

The treatment facilities would be located in proximity to the existing groundwater Wells No. 20 and 44. Well No. 20 is situated on South Triviz Drive to the southwest of the intersection of State Highway 342 and U.S. Interstate 25. See Figure 3 for an aerial photograph with the approximate treatment facility location for Well No. 20. Well No. 44 is situated on Missouri Avenue to the southeast of the intersection of Missouri Avenue and Gladys Drive. See Figure 4 for an aerial photograph with the approximate treatment facility location for Well No. 44.

If not already available at the site, the facilities would need 480 volt, 3 phase power, connection to natural gas, connection to a sanitary sewer, and connection of potable water piping from groundwater Wells No. 20 and 44. Treated water can be discharged directly to the potable water distribution system.

The power and control system for the facilities would be located along the inside wall of the buildings. The amount of equipment required to power and control the treatment system does not warrant a separate room. Heating, ventilation, and air conditioning would be provided for each treatment area.

See Figures 4, 5, and 6 for the interior layout of the treatment facilities at Wells No. 20 and 44. See Appendix B for an example of a process control schematic for a 2-stage uranium treatment system by WRT.



Well No. 20

Figure 3 – Well No. 20 Location





Well No. 44



Missouri Ave

Corbett Dr

John St

Payne Ct

Gladys Dr

Boise Dr

Figure 4 – Well No. 44 Location



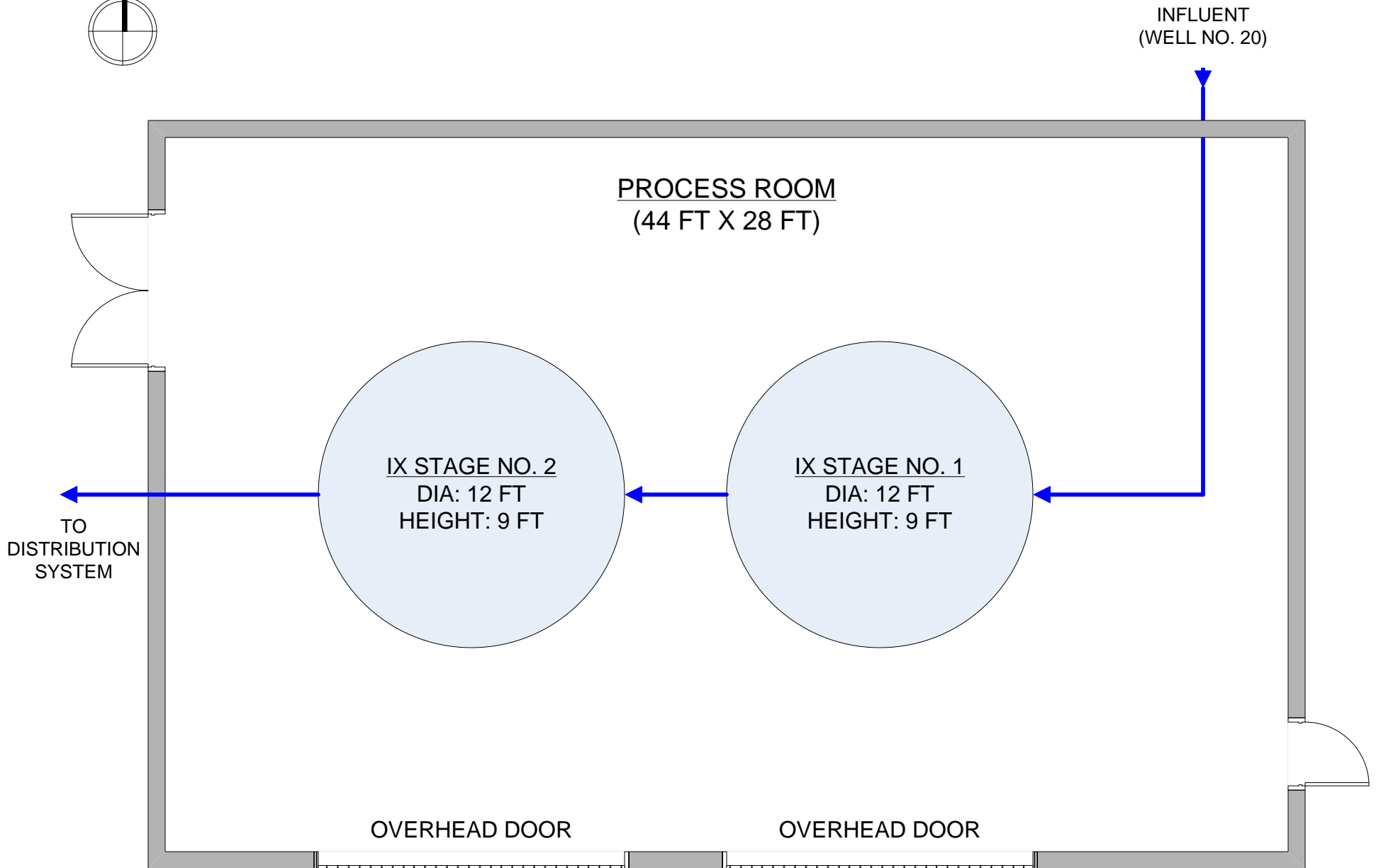
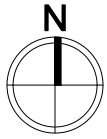

PLAN VIEW

3/16" = 1' - 0"

Figure 5 – Well No. 20 Uranium Treatment Layout (Alternative #1)



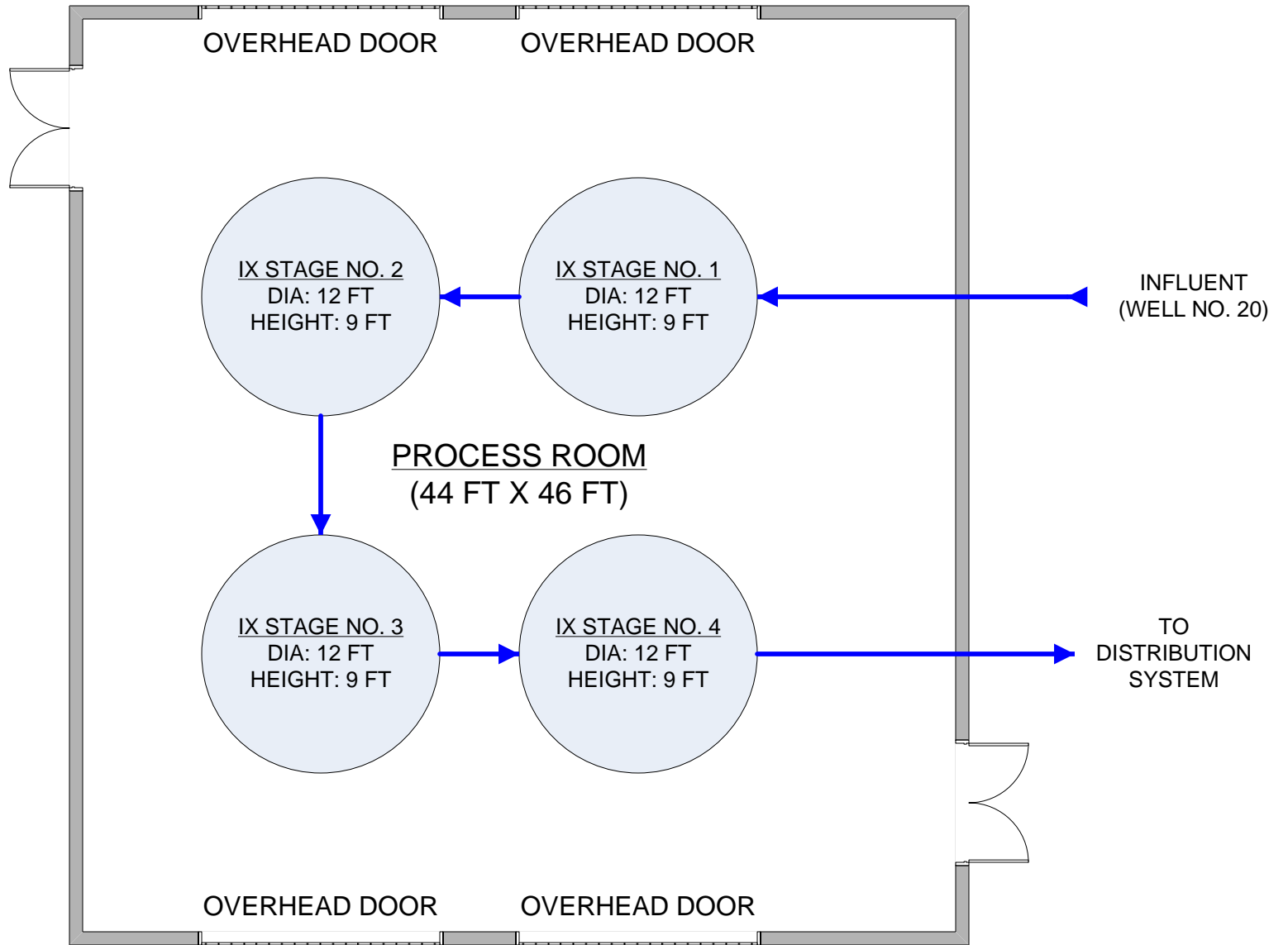

**PLAN VIEW**  
1/8" = 1' - 0"

Figure 6 – Well No. 20 Uranium Treatment Layout (Alternative #2)

CH2MHILL  
City of Las Cruces

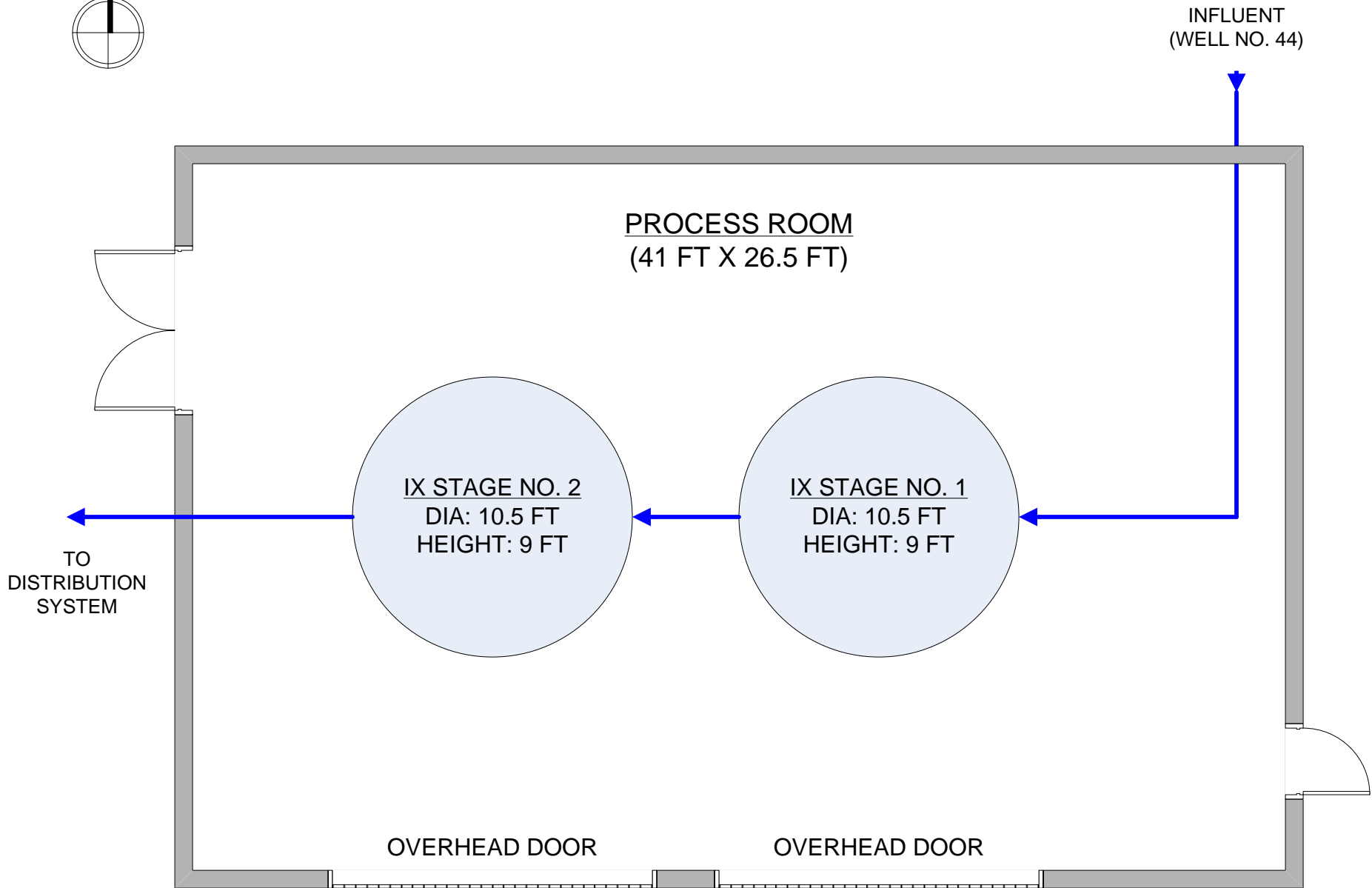
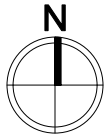

PLAN VIEW

3/16" = 1' - 0"

Figure 7 – Well No. 44 Uranium Treatment Layout





## Opinion of Costs

Costs for Phase III of the facilities were developed and are described below. Capital costs for the project were developed using CH2M HILL's Parametric Cost Estimating System (CPES). Based on this conceptual development, the opinion of cost should be considered a Class 4 cost estimate as defined by the Association for the Advancement of Cost Engineering (AACE International).

This opinion of cost was prepared based on the information where preliminary engineering is from 1 to 5 percent complete and detailed strategic planning, business development, project screening, alternative scheme analysis, confirmation of economic and/or technical feasibility and preliminary budgetary approval are necessary to proceed. Examples of estimating methods used to include equipment and/or system process factors, scale-up factors, and parametric and modeling techniques. The typical expected accuracy range for this class of estimate is minus 20 percent on the low side and plus 30 percent on the high side. The final costs of the project will depend on actual labor and material costs, competitive market conditions, actual site conditions, final project scope, implementation schedule, continuity of personnel and engineering, and other variable factors. Therefore, the final project costs will likely vary from the estimate presented.

Costs are presented in 2007 dollars, current to the date of this TM, for the proposed treatment project. Capital costs include construction, engineering, engineering services during construction, permitting, commissioning and startup, and legal services. Costs for raw water development and land purchase are not included in this estimate.

The estimate includes the following contractor markups and allowances:

- Mobilization, bonds, and insurance                      3%
- Contractor's overhead                                              10%
- Contractor's profit                                                      7%

The estimate also includes a 30-percent contingency, which is appropriate for this level of project definition and completion. The estimated costs have been escalated to the approximate midpoint of construction, assumed as July 2008.

Annual O&M costs were developed for each alternative. These costs assume a contract term of 20 years between the City and the IX supplier. The price will be adjusted manually, based upon the Consumer Price Index (CPI). These annual costs include the following services from the IX supplier:

- Maintain system during period of contract
- Handling of all media
- Transport and disposal of all media
- Operating analytical fees (analysis of samples required by IX supplier for operational monitoring)

The annual costs in this estimate do not include O&M services provided by the City.

Including all of these assumptions, the estimated construction and O&M costs for the uranium treatment systems at Wells No. 20 and 44 are presented in Table 2.

TABLE 2  
Costs for Well Head Uranium Treatment

Well No.	Construction Costs	Non-Construction Costs	Capital Costs	Annual O&M Costs <sup>(1)</sup>	Additional O&M (\$/1,000 gal)
20 (Alt. #1)	\$3,118,200	\$842,000	\$3,960,200	\$235,718	\$1.40
20 (Alt. #2)	\$5,824,400	\$1,572,600	\$7,397,000	\$128,810	\$0.73
44	\$2,675,000	\$722,200	\$3,397,200	\$40,090	\$0.43

(1) Annual O&M costs based on annual production rates presented in Table 1. Costs cover services of IX supplier only. Contract O&M costs will be adjusted annually, based upon the Consumer Price Index (CPI). Contract term is 20 years.

(2) Additional O&M costs apply when the annual production rates presented in Table 1 are exceeded.

Appendix B presents a detailed breakdown of construction costs for uranium treatment at Wells No. 20 and 44.

## Implementation – Contracting Processes

A contracting process for specialized water treatment equipment has been developed to offer a fair and competitive environment. The process contains the following three contract phases:

- Design & Bidding Services Contract
- Construction Contract
- Long-term Operational Assistance Contract

These contracts are presented in the following discussion.

### Design & Bidding Services Contract

This contract phase includes design services, services during bidding, services during construction, and startup services. Design services include the selection and location of the treatment system, coordination with mechanical, electrical, and instrumentation disciplines, locating the system on the site, and the engineering calculations necessary for the treatment process. Additionally, preparation of design drawings, technical specifications, and contract documents for each phase is part of the design services contract.

### Construction Contract

The construction contract will be with a single construction contractor. This contractor will purchase all equipment, coordinate delivery, install the equipment, and construct all other items pertaining to the treatment facility, such as piping, electrical, or concrete work. Installation will be in accordance with the engineering design drawings.

The contractor must supply the water treatment equipment provided by the long-term operations contractor selected.



## Long-term Operational Assistance Contract

The City's Utilities Department (Water Division) will be responsible for the day-to-day operations of the treatment systems. The spent media from the IX process will contain elevated levels of uranium; therefore, the use of a Contractor is anticipated for the disposal of this material. It is expected that the long-term operational assistance of the uranium treatment facility will be contracted with the supplier of the uranium removal equipment. Operational assistance activities include:

- Regular removal and replacement of the ion-exchange media. Removal to include long-term disposal of the material through an identified source.
- Training of City staff to ensure health and safety when working around the treatment system. This is to occur at identified periods.
- Supply of spare parts for the treatment equipment. Respond to periodic requests by City staff for equipment.
- Provision of safety equipment (dosimeter badges) and other minor items.
- Regular testing of the media and the water to determine uranium concentrations or other selected parameters.

## Qualifications Based Selection of Equipment

There are two manufacturers of non-regenerating IX systems for uranium removal listed in Appendix A. Each of these manufacturers can likely provide water treatment equipment that will meet the uranium removal goals of the City of Las Cruces. However, the handling and disposal of spent media may be a challenge to some manufacturers. Therefore, it is recommended that the City utilize a qualifications based process to select an IX supplier that can adequately and safely meet the O&M needs of the City.

A qualifications based selection process provides the City with the ability to select an IX supplier that meets both the treatment and O&M needs of the City. Design would be completed using a normal process. During the design, the equipment selection could be completed using a qualifications based process where proposals are requested from IX suppliers. The selected equipment would then be incorporated into the construction contract to ensure that the facility is coordinated and constructed completely.

This qualifications based equipment selection process would proceed as follows:

1. Set preliminary design parameters for the equipment and O&M contract. Develop advertisement and request for proposal. Develop a list of equipment suppliers.
2. Send advertisement to equipment suppliers requesting written proposal, an interview, a list of recent completed projects, and references. Other specific items can also be required.
3. Written proposals received and reviewed by a City selection committee.
4. Interviews completed by equipment suppliers. This is optional, but allows interaction and questions for proposals that may be less complete in some areas. This also includes a way for the suppliers to bring equipment or demonstrations to the presentation.

5. Selection committee visits other installations or, at a minimum, calls the references of the equipment suppliers. Selection committee meets and picks the best-qualified equipment supplier.
6. Notification of short-listed status sent to the selected equipment supplier. Letter includes a request to provide costs for the installation and the O&M contract. Design parameters are finalized and included to the equipment supplier at this time.
7. Costs received by the selection committee. The engineering consultant provides an evaluation of the costs based on engineering judgment and compared to previous projects awarded in the last 5 years.
8. If costs are acceptable, the contract is awarded to the selected equipment supplier. An agreement is completed that can be inserted into a construction contract. If costs are not acceptable the supplier can either adjust the costs to an agreed upon level or the selection committee can move to the second ranked equipment supplier and negotiate costs with this company.
9. The agreement would be split into two areas, one for the construction contract and a second for long-term operation. The costs for both the construction contract and long-term operation contract would be finalized at this point.
10. The design of the system is finalized including bidding documents. The bidding documents include the agreement with the equipment supplier and the bid form includes a fixed cost listed as a line item for the equipment. The construction contractor adds a lump sum amount for work in addition to the supplied equipment.
11. Bidding is finalized using the City's normal procedure for construction contracts. Bidders are required to include with their bid a letter from the equipment supplier stating that they are willing to contract with this firm. Bids for the construction contract are awarded based on lowest responsive bid.
12. Construction of the system proceeds with the construction contractor contracted to the equipment supplier for the installation. The construction contractor provides needed manpower for the installation and startup of the system. The construction contract is completed using the City's standard procedures (substantial completion and final completion).
13. Long-term operation of the system is then governed by the long-term portion of the agreement with the equipment supplier. The construction contractor is no longer involved. Normal operation of the system is completed by City staff with training by the equipment supplier.

## **APPENDIX A - List of Manufacturers**

---

# List of Equipment Manufacturers

---

The following is a list of equipment manufacturers for non-regenerative ion exchange systems designed for uranium removal. This is not a complete list of all potential suppliers. There may be other suppliers that can provide treatment equipment that can adequately remove uranium.

1. Water Remediation Technology, LLC  
9500 W. 49<sup>th</sup> Avenue, Suite D100  
Wheat Ridge, Colorado 80033  
Telephone: (303) 424-5355  
Web: [www.wrt.net](http://www.wrt.net)
2. Basin Water, Inc.  
8731 Prestige Court  
Rancho Cucamonga, California 91730  
Telephone: (909) 481-6800  
Web: [www.basinwater.com](http://www.basinwater.com)

See the attached Reference List from Water Remediation Technology, LLC, for facilities operating uranium removal systems.



## REFERENCE LIST

Water Remediation Technology, LLC.  
9500 West 49<sup>th</sup> Ave. Suite D100  
Wheat Ridge, CO 80033  
Phone: (303) 424-5355  
Fax: (303) 425-7497  
www.wrt.net.com

### **PROJECT: Fox Run Water Company, Virginia**

One existing well: 80 GPM

Mac Bugg; Consulting Engineer - B&B Consultants	434-447-7621
Bernard Nash; Manager - Fox Run Water Company	434-636-5360
David Horne; Engineering Field Director – Virginia Dept. of Health	630-365-5060

### **PROJECT: United Water: Sussex, New Jersey**

One existing well: 60 GPM

Tony Vicente; United Water – Operations Manager	201-634-4255
-------------------------------------------------	--------------

### **PROJECT: Bass Lake Water Company, Bass Lake, California**

One well: 125 GPM

Mark Reitz; Consulting Engineer – Boyle Engineering Corporation	559-448-8222
Stephen Welch; President – Bass Lake Water Company	559-642-2494
Bonnie Bessemer; Health Physicist, CDHS/Rad Materials Licensing	916-440-7902

FROM SOURCE TO SOLUTION™



## **APPENDIX B - Process Control Schematic**

---

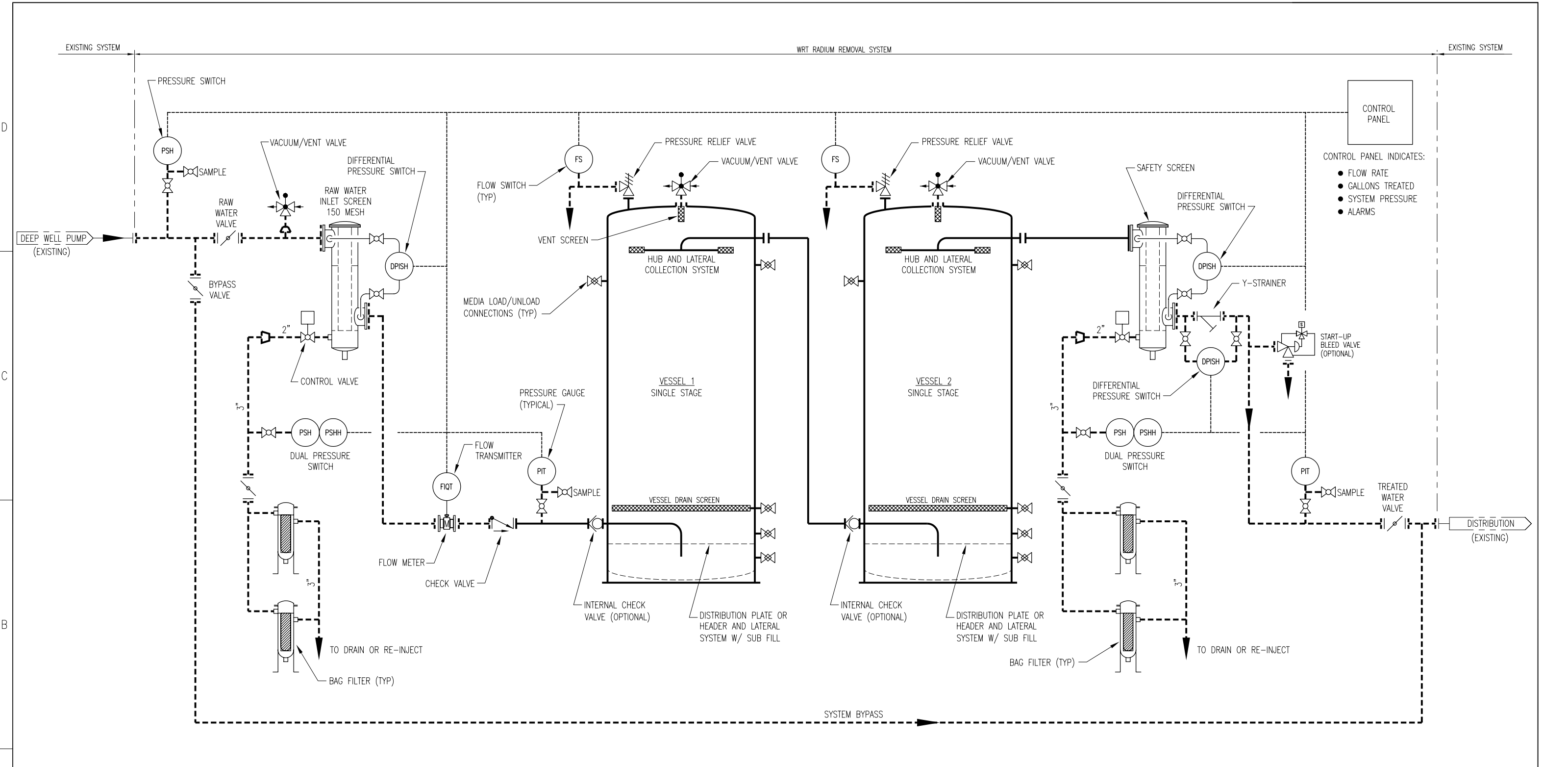

CONTROL PANEL INDICATES:

- FLOW RATE
- GALLONS TREATED
- SYSTEM PRESSURE
- ALARMS

- NOTES:
1. ALL VALVES AND COMPONENTS SHOWN WILL BE SUPPLIED BY WRT.
  2. CLIENT SHALL BE RESPONSIBLE FOR PROCURING ALL PIPING (EXCEPT AS NOTED), FITTINGS, GASKETS & HARDWARE, SUPPORTS, AND OTHER APPURTENANCES REQUIRED FOR A COMPLETE SYSTEM.
  3. CLIENT SHALL BE RESPONSIBLE FOR THE INSTALLATION OF ALL COMPONENTS INCLUDING THOSE SUPPLIED BY WRT.

— INDICATES PIPING AND EQUIPMENT SUPPLIED BY WRT  
 - - - INDICATES PIPING AND COMPONENTS SUPPLIED BY OTHERS

THIS DRAWING AND THE CONTENTS THEREOF ARE THE PROPERTY OF WATER REMEDIATION TECHNOLOGY, LLC (WRT) AND MAY NOT BE COPIED WITHOUT THE EXPRESS WRITTEN CONSENT OF WRT. THIS DRAWING CONTAINS PROPRIETARY INFORMATION, AND MAY NOT BE USED IN ANY WAY THAT WOULD BE DETRIMENTAL TO WRT. ALL WRT EQUIPMENT AND TREATMENT PROCESSES ARE PROTECTED BY PATENTS AND TRADEMARKS FOREIGN AND DOMESTIC, ISSUED AND PENDING.



**WATER REMEDIATION TECHNOLOGY**  
**WHEAT RIDGE, COLORADO**

URANIUM REMOVAL SYSTEM  
 DUAL TANK SYSTEM

TYPICAL SCHEMATIC

**APPENDIX C - Opinion of Costs Detail**

---



**Estimate of Probable Capital Costs**  
 Uranium Treatment - Phase II Conceptual Design  
 City of Las Cruces

**PROJECT SCOPE**

Treatment for Well No. 20 (Alternative #1), complete.

<b>PROJECT ITEMS</b>	<b>COST</b>
<b>Construction Costs</b>	
Treatment Equipment	
<i>WRT Ion Exchange System, 2 tanks (includes installation and delivery)</i>	\$ 632,500
<i>Magnetic flow meter, 1 unit</i>	\$ 7,200
<i>Miscellaneous items</i>	\$ 31,985
Treatment Building	
<i>Building, 1,232 square feet</i>	\$ 277,200
<i>Process Piping</i>	\$ 83,027
<i>Finishes</i>	\$ 47,444
<i>Instrumentation and Controls</i>	\$ 59,305
<i>Mechanical Systems (HVAC &amp; Plumbing)</i>	\$ 118,611
<i>Electrical Systems</i>	\$ 59,305
Site Work	
<i>Site Civil (earthwork)</i>	\$ 157,989
<i>Plant Computer (RTU and Controls)</i>	\$ 111,909
<i>Site Electrical (Service)</i>	\$ 96,110
<i>Yard Piping</i>	\$ 131,658
Contractor Markups	
<i>Overhead</i>	10.0% \$ 181,424
<i>Profit</i>	7.0% \$ 139,697
<i>Mobilization/Bonds/Insurance</i>	3.0% 64,061
Adjustments	
<i>Contingency</i>	30% 659,828
<i>Escalation (to Mid-Point of Construction)</i>	18.45% \$ 527,558
<i>Location Adjustment Factor (Las Cruces) Deduct</i>	83.70% \$ (552,050)
<i>Market Adjustment Factor</i>	10% \$ 283,476
<hr/>	
<b>CONSTRUCTION COSTS - SUBTOTAL</b>	<b>\$ 3,118,238</b>
<hr/>	
<b>Non-Construction Costs</b>	
<i>Permitting</i>	
<i>Engineering</i>	
<i>Engineering Services During Construction</i>	
<i>Commissioning and Startup</i>	
<i>Legal and Administrative</i>	
<i>Subtotal</i>	27% \$ 841,924
<hr/>	
<b>NON-CONSTRUCTION COSTS - SUBTOTAL</b>	<b>\$ 841,924</b>
<hr/>	
<b>CAPITAL COSTS - TOTAL</b>	<b>\$ 3,960,162</b>

**Estimate of Probable Capital Costs**  
 Uranium Treatment - Phase II Conceptual Design  
 City of Las Cruces

**PROJECT SCOPE**

Treatment for Well No. 20 (Alternative #2), complete.

<b>PROJECT ITEMS</b>	<b>COST</b>
<b>Construction Costs</b>	
Treatment Equipment	
<i>WRT Ion Exchange System, 4 tanks (includes installation and delivery)</i>	\$ 1,247,060
<i>Magnetic flow meter, 1 unit</i>	\$ 7,200
<i>Miscellaneous items</i>	\$ 62,713
Treatment Building	
<i>Building, 2,024 square feet</i>	\$ 455,400
<i>Process Piping</i>	\$ 155,083
<i>Finishes</i>	\$ 88,619
<i>Instrumentation and Controls</i>	\$ 110,773
<i>Mechanical Systems (HVAC &amp; Plumbing)</i>	\$ 221,547
<i>Electrical Systems</i>	\$ 110,773
Site Work	
<i>Site Civil (earthwork)</i>	\$ 295,100
<i>Plant Computer (RTU and Controls)</i>	\$ 209,029
<i>Site Electrical (Service)</i>	\$ 179,519
<i>Yard Piping</i>	\$ 245,917
Contractor Markups	
<i>Overhead</i>	10.0% \$ 338,873
<i>Profit</i>	7.0% \$ 260,932
<i>Mobilization/Bonds/Insurance</i>	3.0% 119,656
Adjustments	
<i>Contingency</i>	30% 1,232,459
<i>Escalation (to Mid-Point of Construction)</i>	18.45% \$ 985,399
<i>Location Adjustment Factor (Las Cruces) Deduct</i>	83.70% \$ (1,031,147)
<i>Market Adjustment Factor</i>	10% \$ 529,491
<b>CONSTRUCTION COSTS - SUBTOTAL</b>	
	<b>\$ 5,824,396</b>
<b>Non-Construction Costs</b>	
<i>Permitting</i>	
<i>Engineering</i>	
<i>Engineering Services During Construction</i>	
<i>Commissioning and Startup</i>	
<i>Legal and Administrative</i>	
<i>Subtotal</i>	27% \$ 1,572,587
<b>NON-CONSTRUCTION COSTS - SUBTOTAL</b>	
	<b>\$ 1,572,587</b>
<b>CAPITAL COSTS - TOTAL</b>	
	<b>\$ 7,396,984</b>

**Estimate of Probable Capital Costs**  
 Uranium Treatment - Phase II Conceptual Design  
 City of Las Cruces

**PROJECT SCOPE**

Treatment for Well No. 44, complete.

<b>PROJECT ITEMS</b>	<b>COST</b>
<b>Construction Costs</b>	
Treatment Equipment	
<i>WRT Ion Exchange System, 2 tanks (includes installation and delivery)</i>	\$ 535,210
<i>Magnetic flow meter, 1 unit</i>	\$ 7,200
<i>Miscellaneous items</i>	\$ 27,121
Treatment Building	
<i>Building, 1,087 square feet</i>	\$ 244,463
<i>Process Piping</i>	\$ 71,224
<i>Finishes</i>	\$ 40,700
<i>Instrumentation and Controls</i>	\$ 50,875
<i>Mechanical Systems (HVAC &amp; Plumbing)</i>	\$ 101,749
<i>Electrical Systems</i>	\$ 50,875
Site Work	
<i>Site Civil (earthwork)</i>	\$ 135,530
<i>Plant Computer (RTU and Controls)</i>	\$ 96,000
<i>Site Electrical (Service)</i>	\$ 82,447
<i>Yard Piping</i>	\$ 112,942
Contractor Markups	
<i>Overhead</i>	10.0% \$ 155,633
<i>Profit</i>	7.0% \$ 119,838
<i>Mobilization/Bonds/Insurance</i>	3.0% 54,954
Adjustments	
<i>Contingency</i>	30% 566,028
<i>Escalation (to Mid-Point of Construction)</i>	18.45% \$ 452,561
<i>Location Adjustment Factor (Las Cruces) Deduct</i>	83.70% \$ (473,572)
<i>Market Adjustment Factor</i>	10% \$ 243,178
<hr/>	
<b>CONSTRUCTION COSTS - SUBTOTAL</b>	<b>\$ 2,674,955</b>
<hr/>	
<b>Non-Construction Costs</b>	
<i>Permitting</i>	
<i>Engineering</i>	
<i>Engineering Services During Construction</i>	
<i>Commissioning and Startup</i>	
<i>Legal and Administrative</i>	
<i>Subtotal</i>	27% \$ 722,238
<hr/>	
<b>NON-CONSTRUCTION COSTS - SUBTOTAL</b>	<b>\$ 722,238</b>
<hr/>	
<b>CAPITAL COSTS - TOTAL</b>	<b>\$ 3,397,192</b>